



Internet Desktop Phone for Skype™

XS2008CA User Manual



Safety Instructions

Please read the following instructions carefully before starting to use the XS2008CA.

- Always read the safety instructions carefully.
- Keep this User Manual for future reference.
- Keep the unit away from humidity.
- Place the unit on a reliable flat surface before setting it up
- If any of the following situation arises, have the unit checked by a service technician:
 - The unit has been exposed to moisture.
 - The unit has been dropped and damaged.
 - The unit has obvious sign of breakage.
- Do not place the basic unit in a damp room at a distance of less than 1.5 m from a water source. Keep water away from the telephone.
- Do not use the telephone in environments where there is a risk of explosions.
- Maintain the telephone in an environment-friendly manner.

Note: Skype™ does not allow emergency calls. Such calls should be made with a traditional telephone or a mobile phone.

Table of Contents

TABLE OF CONTENTS	3
1. INTRODUCTION	6
1.1 Package Contents.....	6
1.2 Front & Rear Views.....	7
2. ALPHANUMERIC KEYPAD	9
3. HARDWARE INSTALLATION	10
4. SETTING UP THE PHONE	12
4.1 Select Language.....	12
4.2 Accept Agreement.....	12
4.3 Sign in to Skype.....	13
4.3.1 <i>Login with an Existing Account</i>	13
4.4 Create New Account.....	15
5. MAIN SCREEN	16
6. MENU SCREEN	17
7. CONTACTS	18
7.1 Call a Skype Contact.....	18
7.2 Send Voicemail.....	19
7.3 View Profile.....	20
7.4 Advanced Options.....	21
7.4.1 <i>Rename a Contact</i>	22
7.4.2 <i>Remove a Contact</i>	22
7.4.3 <i>Block/ Unblock a Contact</i>	23
7.4.4 <i>Request Contact Details</i>	23
7.4.5 <i>Add a Contact</i>	23
8. HISTORY	25

9. STATUS	26
9.1 Change Status.....	27
9.2 Mood Message	28
9.3 Select My Profile	29
9.3.1 <i>Select Details to be Shown</i>	29
9.3.2 <i>Private Details</i>	30
9.4 Switch User	31
9.5 Sign out	32
10. SEARCH	33
11. SERVICES	35
12. SETTINGS.....	36
12.1 General Settings.....	37
12.1.1 <i>Change Password</i>	37
12.1.2 <i>Auto Sign in</i>	38
12.1.3 <i>Language</i>	39
12.1.4 <i>Software Updates</i>	40
12.1.5 <i>Reset</i>	41
12.2 Call Divert.....	42
12.2.1 <i>Call Forwarding</i>	42
12.2.2 <i>Forward to Voice Mail</i>	43
12.2.3 <i>Set Welcome Message</i>	44
12.3 Privacy	45
12.3.1 <i>Set Allowed Calls</i>	45
12.3.2 <i>SkypeIn Calls</i>	46
12.3.3 <i>Blocked Users</i>	46
12.4 Tones Setting	47
12.4.1 <i>Incoming Call Alert</i>	47
12.4.2 <i>Ring Tone</i>	48
12.4.3 <i>Ring Volume</i>	49
12.4.4 <i>Notification Tones</i>	49
12.4.5 <i>Set Keypad Tones</i>	50

12.5 Time and Date.....	51
12.6 Manage Blocked Users	51
12.7 Network	52
12.7.1 Set Network Type	52
12.8 Phone Settings.....	53
12.8.1 Brightness	53
12.8.2 Timeout.....	54
12.9 Information.....	55
12.10 Advanced.....	57
12.10.1 Software Updates	57
12.10.2 Network Proxy.....	58
12.10.3 Skype Ports.....	59
Appendix A: Specification.....	60

1. INTRODUCTION

Thank you for purchasing the Tecom Desktop phone XS2008CA. This phone is designed for making calls over the Internet, using the Skype® software.

Note: Please make sure you have a working Internet connection. Tecom recommends connecting the XS2008CA to an available port from a router.

Package Contents

- XS2008CA x 1
- Handset with curl cord x 1
- Ethernet cable x 1
- Power adapter x 1
- User Manual (CD Version)
- Installation guide

Front & Rear Views

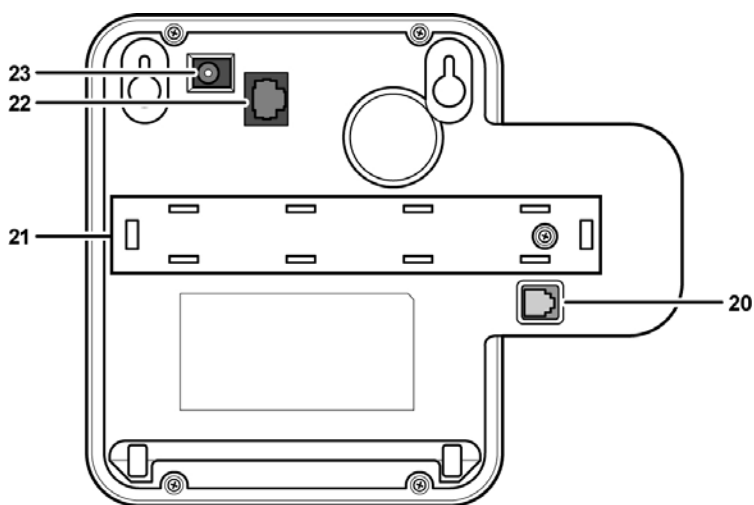
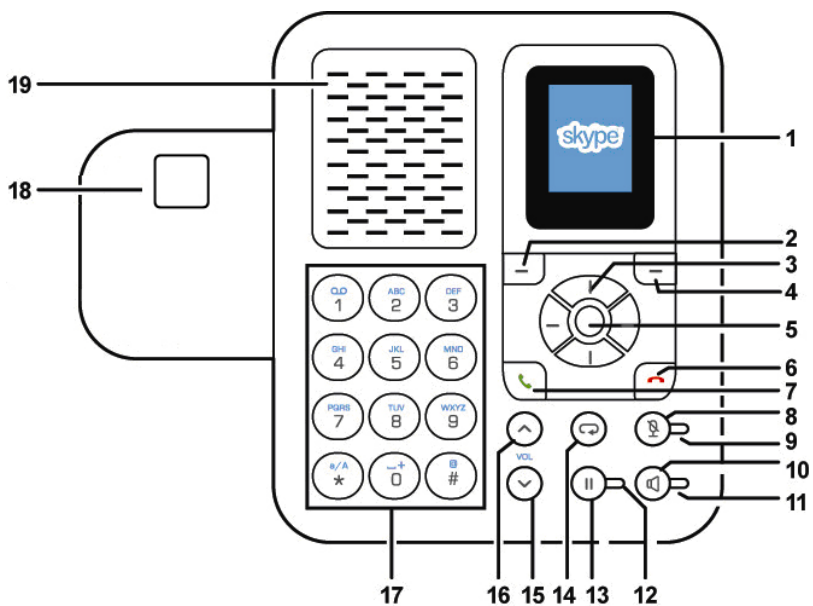

No.	Description
1	LCD screen
2	Left soft button
3	Navigation button
4	Right soft button
5	OK/Enter button
6	End button
7	Call button
8	Mute button
9	Mute LED
10	Speaker button
11	Speaker LED
12	Pause LED
13	Pause button
14	Return button
15	Volume down button
16	Volume up button
17	Alphanumeric keypad
18	Hook switch
19	Hands free speaker
20	Handset (RJ9) jack
21	Compartment
22	Ethernet (RJ45) jack
23	Power Jack

2. ALPHANUMERIC KEYPAD

Refer to the table below when using the alphanumeric keypad. When entering usernames or passwords, you can press the  key to toggle between numbers (123), lower case (abc) and upper case (ABC) characters.

Key	Lower Case (abc)	Upper case (ABC)
1	1 . , ? ! - _	1 . , ? ! - _
2	a b c 2	A B C 2
3	d e f 3	D E F 3
4	g h i 4	G H I 4
5	j k l 5	J K L 5
6	m n o 6	M N O 6
7	p q r s 7	P Q R S 7
8	t u v 8	T U V 8
9	w x y z 9	W X Y Z 9
0	[SPACE] + 0	
*	Toggle between: Numerical/ Lower Case/ Upper Case	
#	Special character selection	

3. HARDWARE INSTALLATION

Follow the steps below to install the XS2008CA Skype phone.

1. Mount the stand to the rear of the phone as shown.

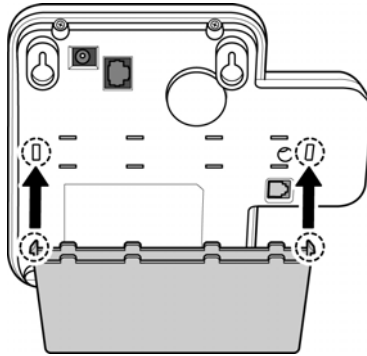

2. Connect the handset to the handset (RJ9) jack as shown.



3. Connect one end of the supplied ethernet cable to the Ethernet (RJ45) jack on the phone. Connect the other end to the network router.

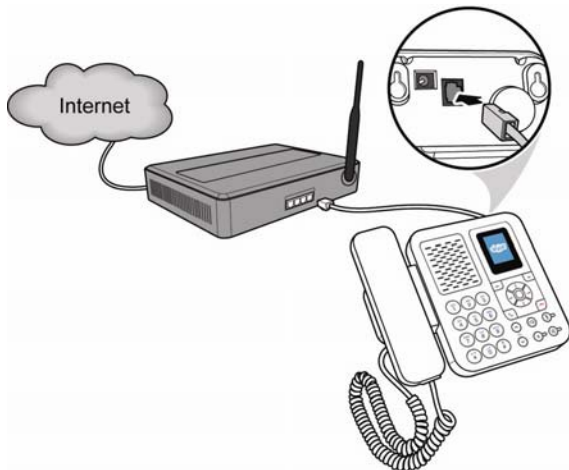

4. Connect one end of the power adapter to the phone's power jack. Plug the power adapter into a mains outlet.

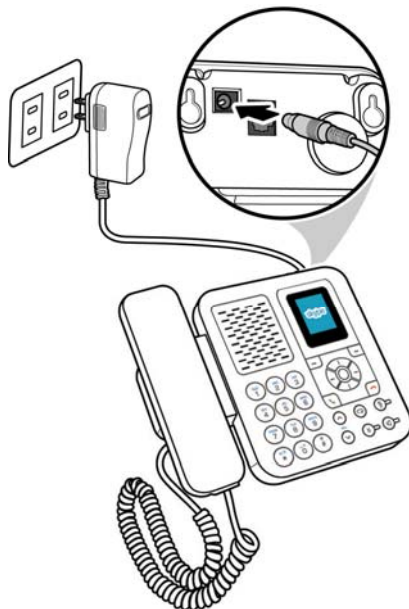

4. SETTING UP THE PHONE

When the phone is powered up for the first time, you need to select the language, accept the agreement, sign in to Skype, or create a new Skype account.

Select Language



- Press the navigation button up or down to select the language of the user interface.
- Press the left soft button to select.

Accept Agreement

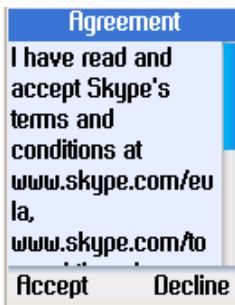

- Press the navigation button down to read the agreement.
- Press the left soft button to accept.

Sign in to Skype

You can configure your phone with an existing Skype account, or you can register a new account (refer to **Create New Account**).

Login with an Existing Account



- Use the navigation button to select **Sign in to Skype**.
- Press the left soft button to select.



- Enter your Skype account name using the alphanumeric keypad.
- Press the left soft button to continue.

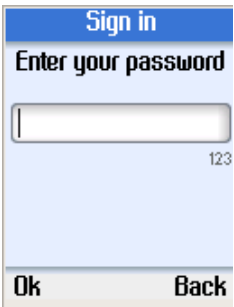

- Enter your Skype password using the alphanumeric keypad.
- Press the left soft button to continue.

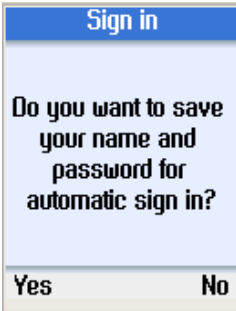

- Press the left soft button to save the user name and the password in the phone.
- Press the right soft button if you don't want to save the password.

Note: When you select to save the user name and the password for automatic sign in, the phone automatically signs in to the account you entered every time it powers up.

1. After you select to save the account information for automatic sign in, you return to the main screen.

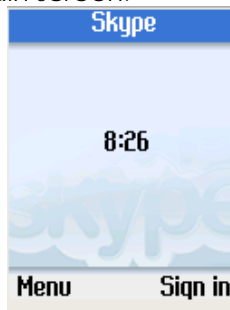

2. If you select not to save the account information, you will go to the Menu (refer to Section 6).

Create New Account

Sign in

Choose option

Sign in to Skype

Create new acc

Select Cancel

- Use the navigation button to select **Create new account**.
- Press the left soft button to select.

New account

Enter Skype name
6 to 32 characters

123

Back

- Enter a unique Skype user name of 6 to 32 characters using the alphanumeric keypad.
- Press the left soft button to continue.

Password

Enter a password
4 to 20 characters

123

Back

- Enter a password of 4 to 20 characters.
- Press the left soft button to continue.

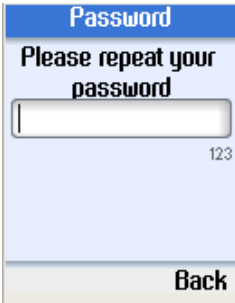

- Enter the password again.
- Press the left soft button to continue.

Note: Please keep your Skype user name and password safe.

5. MAIN SCREEN

The following screen is displayed after you log in to Skype successfully. Press the left soft button to enter the **Menu**, or press the right soft button to enter **Contacts**.

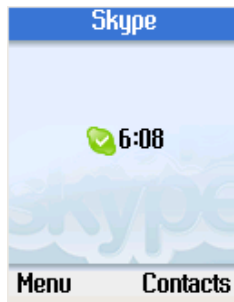

6. MENU SCREEN

On the main display, press the left soft button to enter the Menu. Use the navigation button to select options, and press the left soft button to select.

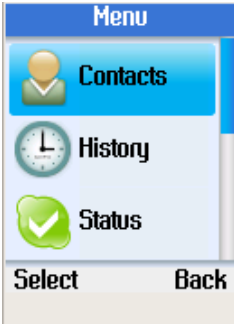

- **Contacts:** Browse your Skype contacts. Refer to Section 7.
- **History:** View your missed calls, incoming and outgoing calls, voicemail, and contact requests. Refer to Section 8.
- **Status:** Change your Skype status (*Offline, Online, Skype Me, Away, Not Available, Do Not Disturb, or Invisible*). Refer to Section 9.

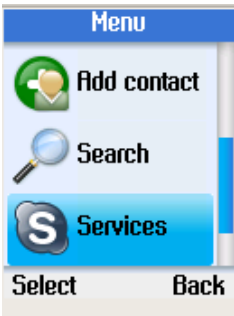

- **Add contact:** Add Skype users or SkypeOut numbers to your contact list. Refer to **Add contact**.
- **Search:** Search for Skype users. Refer to Section 10.
- **Services:** Displays information about your Skype credit balance, your SkypeIn account, and your Skype Voicemail. Refer to Section 11.

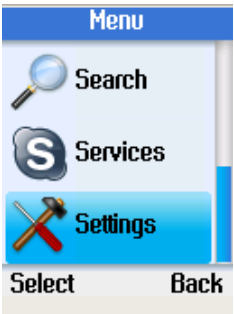

- **Settings:** Change Time and Date, Tones, Network settings, Call divert, Display properties, etc. Refer to Section 12.

7. CONTACTS

Your Skype contacts are stored in your Skype account. When you log in with an existing Skype account, all your contacts will be automatically downloaded to the contact list on the phone.

Call a Skype Contact

Use this option to call the selected contact.

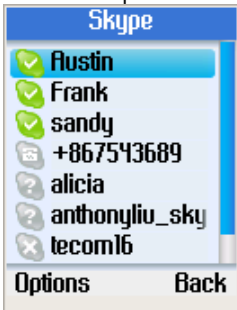

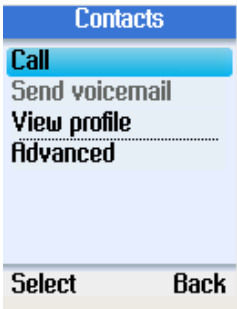

- From the main display, press the right soft button to open the contacts list or press the left soft button to enter the Menu and select **Contacts**.
- A list of your Skype contacts appears.
- Press the left soft button to select **Options**.

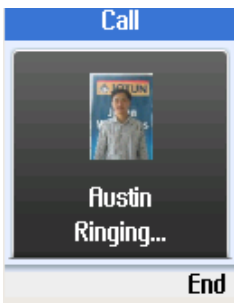

- Use the navigation button to select **Call**.
- Press the left soft button to select.



- Lift the handset and press .
- The call will be made.
- To end the call, hang up the handset and press .

Notes:

- If you do not lift the handset, the phone will automatically go to handsfree mode.
- You can also make calls without entering the Options menu.
Select a contact from your contact list and press  to call.

Send Voicemail

Use this option to send a voicemail message to the selected contact.



- From the main display, press the right soft button to open the contacts list or enter the Menu and select **Contacts**.
- A list of your Skype contacts appears.
- Press the left soft button to select **Options**.

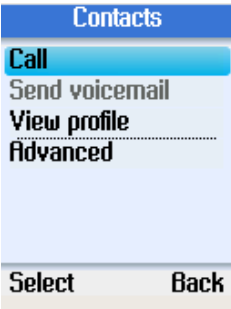

- Use the navigation button to select **Send Voicemail**.
- Press the left soft button to select.

View Profile



- Go to **Contacts**, use the navigation button to select the contact whose profile you want to view.
- Press the left soft button to select **Options**.

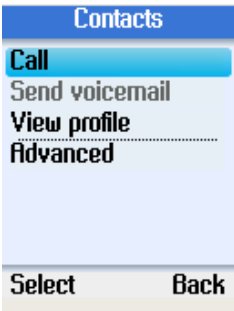

- Use the navigation button to select **User Profile**.
- Press the left soft button to select.



- Use the navigation button to browse the user information of the contact.

Advanced Options

The advanced options menu enables you to rename, remove, block/unblock, or add a contact.



- Go to **Contacts**, use the navigation button to select a contact to view.
- Press the left soft button to select **Options**.

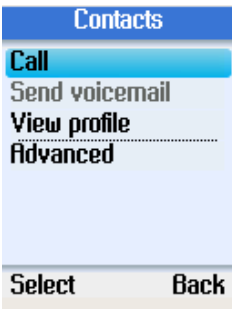

- Use the navigation button to select **Advanced**.
- Press the left soft button to continue.

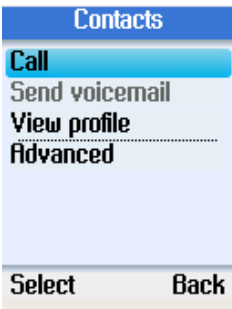

- Use the navigation button to select **Advanced**.
- Press the left soft button to continue.

Rename a Contact

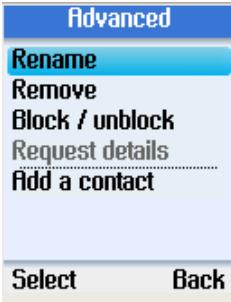

- Use the navigation button to select **Rename** in Advanced options.
- Press the left soft button to continue.



- Enter a new name for the contact using the alphanumeric keypad.
- Press the left soft button to confirm.

Remove a Contact

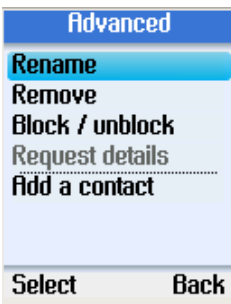

- Use the navigation button to select **Remove** in Advanced options.
- Press the left soft button to continue.
- You can select to remove and block the contact, or remove the contact only.

Block/ Unblock a Contact

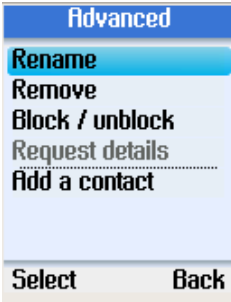

- Use the navigation button to select **Block/ unblock** in Advanced options.
- Press the left soft button to continue.
- You can select to block or unblock the selected contact.

Request Contact Details

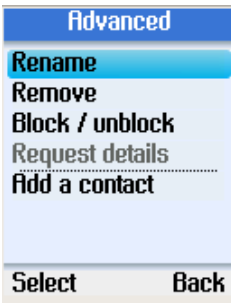

- Use the navigation button to select **Request details** in Advanced options.
- Press the left soft button to continue.
- You can select a contact and send a text message as a request to the user to view his/her status or profile.

Add a Contact

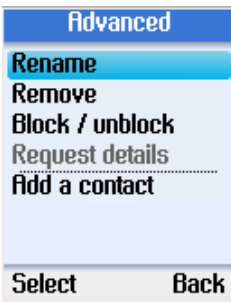

- Use the navigation button to select **Add a contact** in Advanced options
- Press the left soft button to continue.

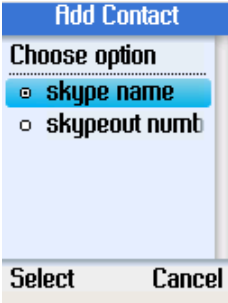

- Use the navigation button to select to add a contact by **Skype name** or **SkypeOut** number.
- Press the left soft button to select.



- To add a contact by Skype name, enter the user name using the alphanumeric keypad.
- Press the left soft button to continue.



- To add a contact by SkypeOut number, enter the number using the alphanumeric keypad.
- Press the left soft button to continue.

8. HISTORY

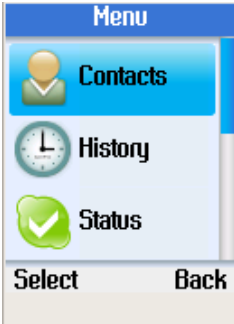

- Press the left soft button to enter the Menu.
- Use the navigation button to select **History**.
- Press the left soft button to enter the History menu.



- Use the navigation button to select an option, and then press the left soft button to select.

The following options are available in the History menu.

Option	Description
All calls	View all calls
Missed calls	View missed calls
Incoming calls	View incoming calls
Outgoing calls	View outgoing calls
Voicemails	View voicemails
Contacts request	View contacts request

9. STATUS

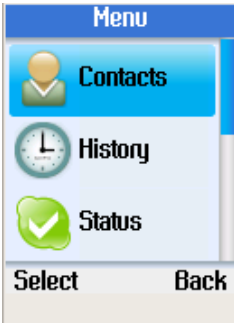

- Press the left soft button to enter the Menu.
- Use the navigation button to select **Status**.
- Press the left soft button to enter the Status menu.

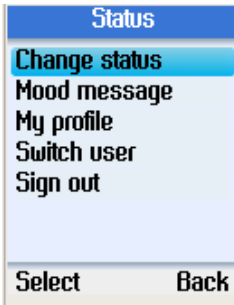

- You can change your Skype status, define mood message, select the profile details to be shown to other users, switch user, or sign out Skype.

Change Status

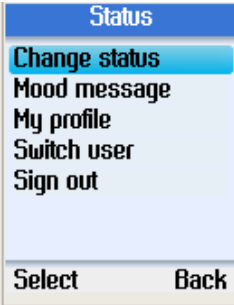

- Use the navigation button to select **Change status**.
- Press the left soft button to continue.

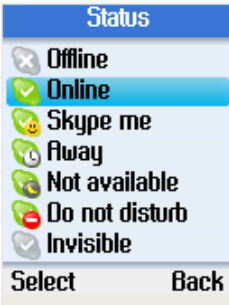

- Use the navigation button to select *Offline, Online, Skype me, Away, Not available, Do not disturb, or Invisible*.
- Press the left soft button to select.

Mood Message

You can enter a message about yourself to be displayed to all your contacts.

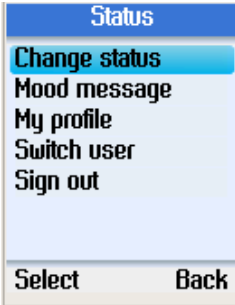

- Use the navigation button to select **Mood message**.
- Press the left soft button to continue.



- Enter your mood message using the alphanumeric keys.
- Press the left soft button to confirm.

Select My Profile

Select the details to be displayed to all your contacts and private details that are not shown to others.

Select Details to be Shown

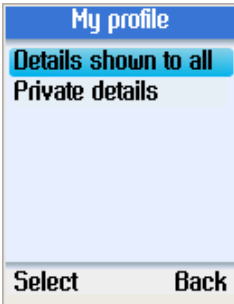

- Use the navigation button to select **Details shown to all**.
- Press the left soft button to continue.



- Use the navigation button to select an item and press the left soft button to continue.
- You can select to shown Skype name, full name, gender, birth date, country/ region, state/ province, city, language, etc. to other contacts.

Private Details

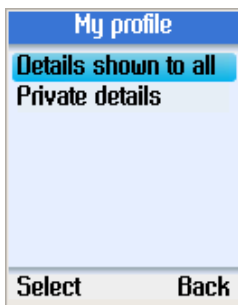

- Use the navigation button to select **Private details**.
- Press the left soft button to continue.

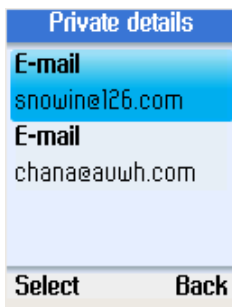

- Select the private details to be displayed to your contacts.

Switch User

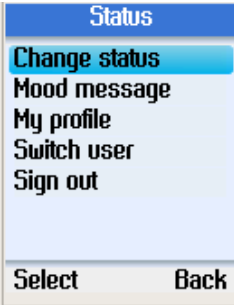

- Use the navigation button to select **Switch user**.
- Press the left soft button to continue.



- Press the left soft button to save your password on the device or the right soft button not to save.



- After signing out, enter a new Skype user name or use the navigation button to select an existing user on the list.
- Press the left soft button to sign in.

Sign out

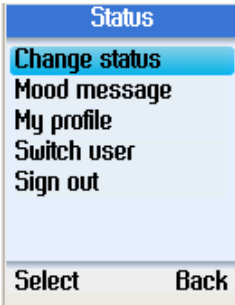

- Use the navigation button to select **Sign out**.
- Press the left soft button to continue.



- Press the left soft button to confirm sign out.

10. SEARCH

You can search for a Skype contact by entering the name or e-mail address of the Skype user.

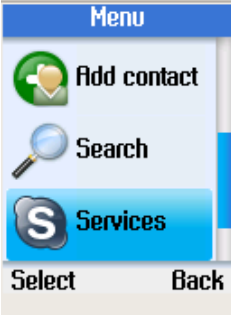

- Press the left soft button to enter the Menu.
- Use the navigation button to select **Search**.
- Press the left soft button to continue.



- Enter the name or e-mail address using the alphanumeric keypad.

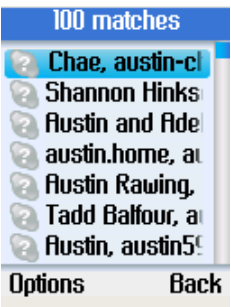

- All the matched results will be shown. If more than one match is found, use the navigation button to select the correct contact.
- Press the left soft button to continue.

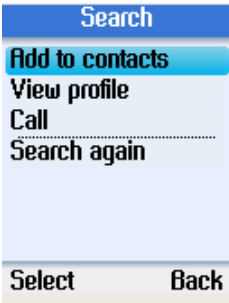

- Use the navigation button to select **Add to contacts** (add user to contact list), **View profile** (view the user's profile), **Call** (call the user), or **Search again** (search one more time).

11. SERVICES

You can view your Skype credit balance, your Skypeln account, and Skype Voicemail. If the services are not active, or you need to buy extra credit, go to www.skype.com for details.

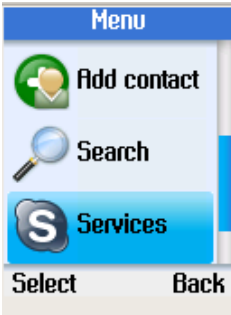

- Press the left soft button to enter the Menu.
- Use the navigation button to select **Services**.
- Press the left soft button to continue.



- Use the navigation button to select **Skype Credit, Skypeln, or Skype Voicemail**.

12. SETTINGS

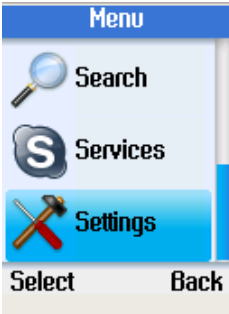

- Press the left soft button to enter the Menu.
- Use the navigation button to select **Settings**.
- Press the left soft button to continue.

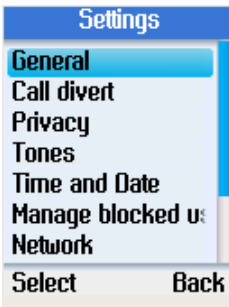

- You can configure the general settings, set call divert, change the date and time, etc.

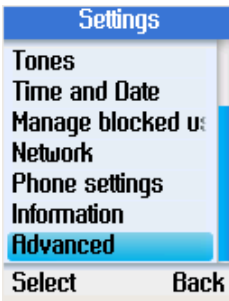

General Settings

In the General settings menu, you can change the Skype password, set automatic sign in, change language of user interface, update software, or reset the phone.



Change Password



- Use the navigation button to select **Change password**.
- Press the left soft button to continue.



- Enter the old password using the alphanumeric keypad.
- Press the left soft button to continue.



- Enter a new password of 4 to 20 characters.
- Press the left soft button to continue.



- Enter the password again.
- Press the left soft button to confirm.

Auto Sign in

You can select to sign in Skype automatically or let the phone prompt for your username and password every time turn it on.



- Use the navigation button to select **Auto sign in**.
- Press the left soft button to continue.



- Select automatic sign in or prompt for password.
- Press the left soft button to confirm.

Language



- Use the navigation button to select **Language**.
- Press the left soft button to continue.



- Use the navigation button to select the language you require.
- Press the left soft button to confirm.

Software Updates



- Use the navigation button to select **Software updates**.
- Press the left soft button to continue.



- Use this option to update the software automatically. To use this option, make sure that you have checked for the automatic software updates via **Settings> Advanced> Software updates**.

Reset



- Use the navigation button to select **Reset**.
- Press the left soft button to continue.



- Select **Reset all** to reset all phone settings, or select to reserve the network configurations and reset other settings.

Call Divert

In the Call Divert menu, you can choose if to divert all your calls to your voicemail.

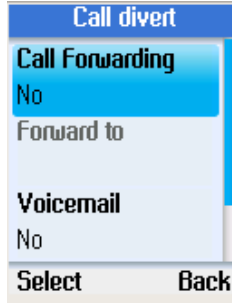

Call Forwarding



- Use the navigation button to select **Call Forwarding**.
- Press the left soft button to continue.

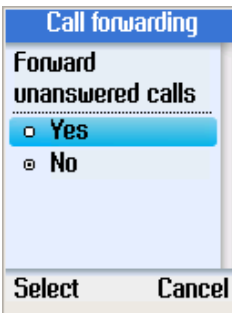

- Select **Yes** to forward unanswered calls to a Skype name.
- Press the left soft button to continue.



- Enter the Skype name using the alphanumeric keypad.
- Press the left soft button to confirm.

Forward to Voice Mail

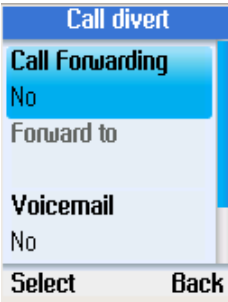

- Use the navigation button to select **Voice Mail**.
- Press the left soft button to continue.

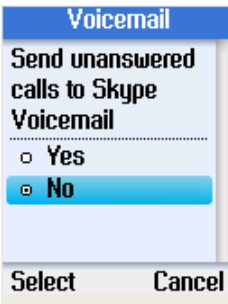

- Select **Yes** to forward unanswered calls to Skype voicemail.
- Press the left soft button to continue.

Set Welcome Message

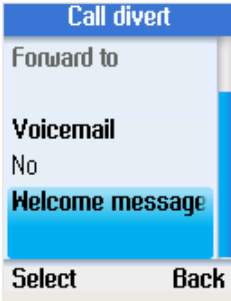

- In Call divert menu, use the navigation button to select **Welcome message**.
- Press the left soft button to continue.



- Record your voice message.

Privacy

In the Privacy menu, you can configure privacy settings for calls, SkypeIn calls, and blocked users.

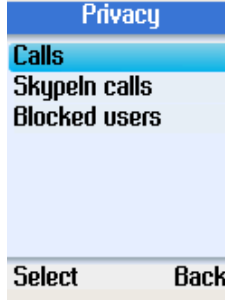

Set Allowed Calls



- Use the navigation button to select **Calls**.
- Press the left soft button to continue.

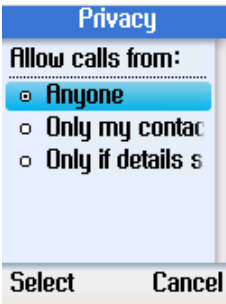

- Select allow calls from anyone, only contacts on your list, or specified contacts.
- Press the left soft button to confirm.

SkypeIn Calls

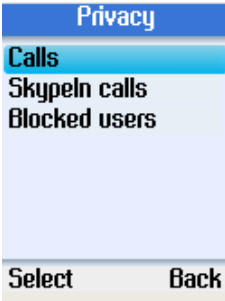

- Use the navigation button to select **SkypeIn Calls**.
- Press the left soft button to continue and set the allowed SkypeIn calls.

Blocked Users



- Use the navigation button to select **Blocked Users**.
- Press the left soft button to continue and browse the information of the blocked users.

Tones Setting

In the Tones Setting menu, you can set the incoming call alert, ring tone, ring volume, notification tones, and keypad tones.

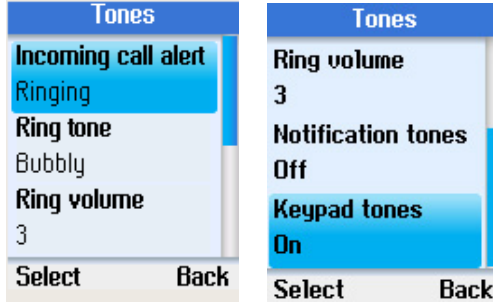

Incoming Call Alert

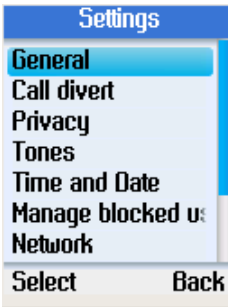

- Select **Tones** in Settings.
- Press the left soft button to continue.



- Use the navigation button to select **Incoming call alert**.
- Press the left soft button to continue.

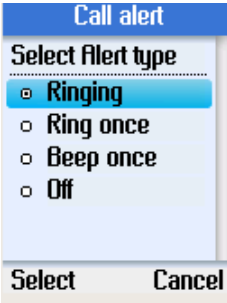

- Select ringing (continuously), ring once, beep one, or turn off the ringing tone.

Ring Tone

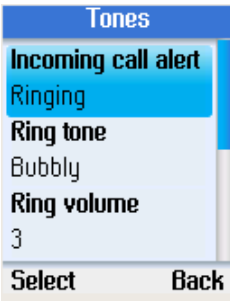

- Use the navigation button to select **Ring tone**.
- Press the left soft button to continue.



There are three preset ring tones. Use the navigation button to select your desired ring tone.

Ring Volume



- Use the navigation button to select **Ring volume**.
- Press the left soft button to continue.

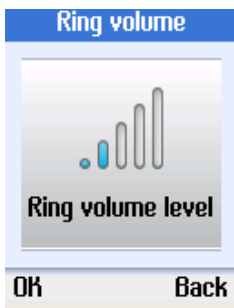

- Use the navigation button to adjust the volume level.
- Press the left soft button to confirm.

Notification Tones

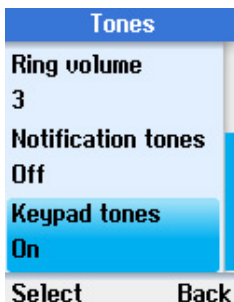

- Use the navigation button to select **Notification tones**.
- Press the left soft button to continue.

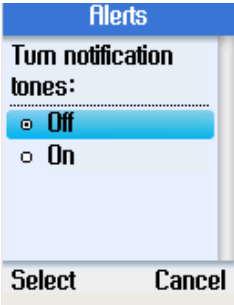

- Use the navigation button to select on or off.

Set Keypad Tones

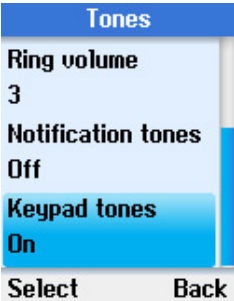

- Use the navigation button to select **Keypad tones**.
- Press the left soft button to continue.



- Use the navigation button to select on or off.

Time and Date

In the Time and Date menu, you can configure time, date, and time zone.

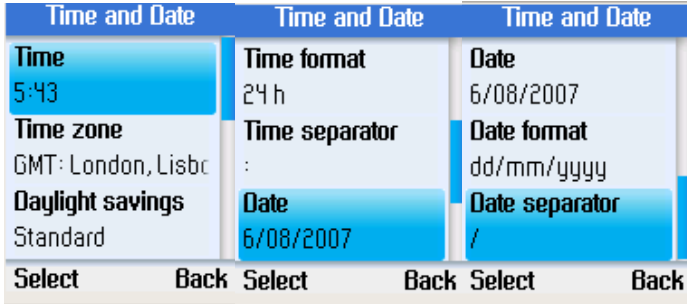

- Select Time and Date in the Settings menu.
- Use the navigation button to select time, time zone, daylight savings, time format, time separator, date, date format, and date separator.
- Press the left soft button to configure each setting.

Manage Blocked Users

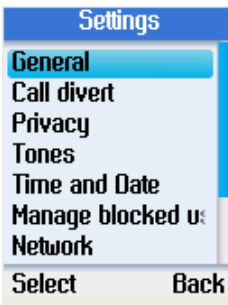

- Select **Manage blocked users** in the Settings menu.
- Press the left soft button to continue. You can browse the information of the blocked Skype contacts.

Network

In the Network menu, you can configure the network connection type, IP address, subnet mask, default gateway, and DNS information of the phone.



Set Network Type

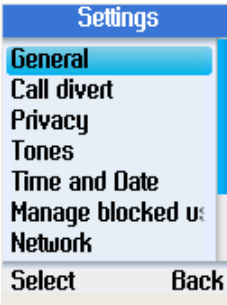

- Select **Network** in Settings.
- Press the left soft button to continue.

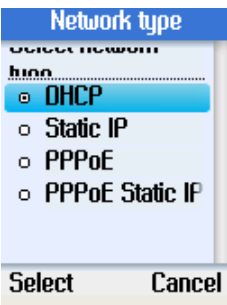

- Select DHCP, Static IP, PPPoE, or PPPoE Static IP for the network connection method used by the phone.



- Unless you are using DHCP, you must enter your IP address, subnet mask, gateway, primary and secondary DNS addresses.

Phone Settings

In the Phone settings menu, you can configure the brightness of the phone display screen, and screen timeout settings.

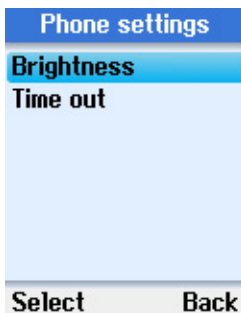

Brightness

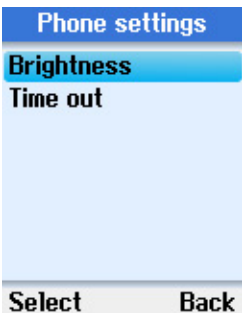

- Use the navigation button to select **Brightness**.
- Press the left soft button to continue.

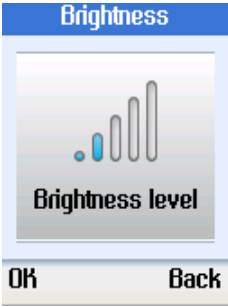

- Use the navigation button to adjust the brightness level.

Timeout

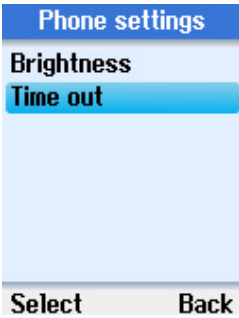

- Use the navigation button to select **Timeout**.
- Press the left soft button to continue.

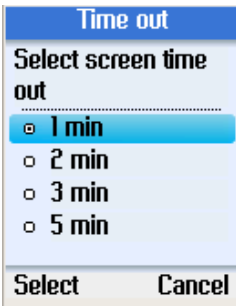

- Use the navigation button to select **1, 2, 3, or 5 min** for screen timeout.

Information

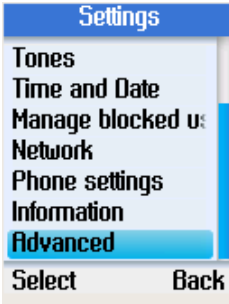

- Select **Information** in Settings.
- Press the left soft button to continue.

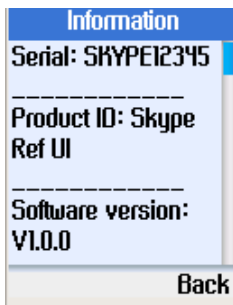

- Press the navigation button up and down to view the information including serial number of the phone, product ID, software version, hardware version, MAC address, and copyright.

Advanced

In the Advanced settings menu, you can update software, and configure network proxy and Skype ports.

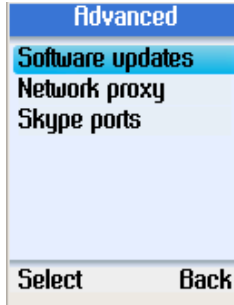

Software Updates



- Use the navigation button to select **Software updates**.
- Press the left soft button to continue.

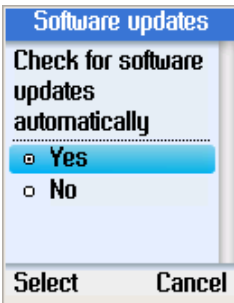

- Use this option to check for software updates.

Network Proxy



- Use the navigation button to select **Network Proxy**.
- Press the left soft button to continue.



- Configure the proxy type for your phone. You can select No proxy, HTTPS, or SOCKS5. When HTTPS or SOCKS5 is selected, you can enter the host name and port number, and select to enable or disable the proxy authentication.

Skype Ports



- Use the navigation button to select **Skype ports**.
- Press the left soft button to continue.



- Configure the port number for incoming connections and the alternative port numbers.

Appendix A: Specification

I. VOICE PERFORMANCE

Handset Receiver

1. Impedance: 150 Ohm +- 20%
2. Input Power: 0.01W / 0.02W (Min./ Max.)

Handsfree Speaker

1. Voice Coil Impedance: 25 Ohm +- 15%
2. Input Power 0.25W

Microphone

1. Sensitivity: -42 +- 2 dB
2. Output Impedance: 2.2 K Ohm

II. Recommended Distance of Handfree mode : 0.5~1.5M

III. Hardware Specification

10/100 Base-T Ethernet with auto MDIX (Full-Duplex)
1.8" LCD 160x128

Sample Rate: 8K

Acoustic Echo Canceller Enabled

Audio Frequency Range: 100Hz - 3400Hz

Network protocol:

DHCP, Static IP, PPPoE, PPPoE Static IP, DNS , TCP/UDP/IPV4

System Requirement:

Broadband Internet (xDSL/Cable), IP sharing Router/Gateway (internet access device).